

Description

Gas discharge tubes (GDT) use noble gasses enclosed in ceramic tubes to provide an alternate circuit path for voltage spikes. The ceramic envelope and with nickel connectors allow for high loads. 2R-4S Gas Discharge Tubes (GDT) series has a surge rating of 3kA, 8/20µs. Offered in a Squared Surface Mount package, which helps to make pick and place on PCB process easier.

This GDT series is perfectly suited for broadband equipment applications. The GDT's low off-state capacitance is compatible with high bandwidth applications and this capacitance loading value does not vary if the voltage across the GDT changes.

2R-4S Gas Discharge Tube (GDT) series are specifically designed for protection of electrical, multimedia, and communication equipment against over voltage transients in surface mount assembly applications.

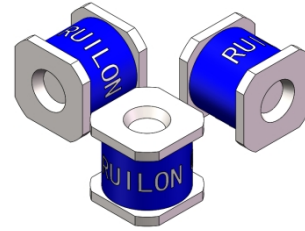

Electrical symbol

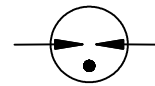

Features

- I Excellent response to fast rising transients
- I Stable breakdown voltage
- I GHz working frequency
- I 8/20µs Impulse current capability:3KA
- I Surface Mount package
- I Non-Radioactive
- I Ultra Low capacitance (<0.8pF)
- I Lead-free compliant
- I RoHS and REACH compliant
- I Size: 4.0mm*4.2mm*4.2mm
- I Storage and operational temperature: -40~+90°C

Applications

- I CATV equipment
- I Antennas
- I RS 485
- I Telecom Base Station
- I Power Supply AC Main
- I EV power Charging
- I Inverter/Variable
- I Frequency Drivers
- I IEEE 802.3 compliant Ethernet interfaces
- I Broad Band equipment
- I xDSL, ADSL, ADSL2, VDSL, and VDSL2
- I Medical Electronics
- I Test Equipment
- I General Telecom Equipment
- I Renewable Energy

Part Number Code

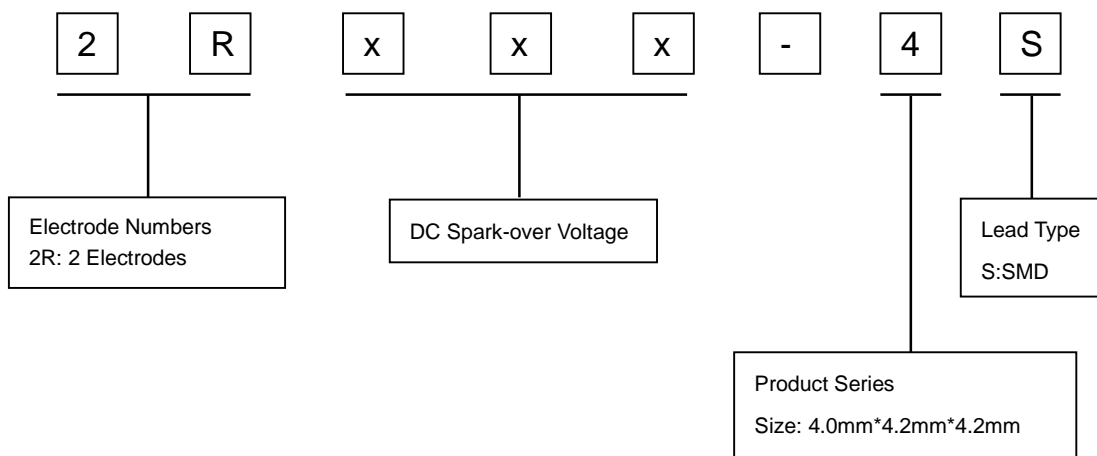

Electrical Characteristics

Part Number	DC Spark-over Voltage ¹⁾²⁾ @100V/S	Impulse Spark-over Voltage		Insulation Resistance ³⁾	Capacitance @1MHz	Service Life			
		100V/ μ S	1KV/ μ S			Impulse Discharge Current @8/20 μ S		AC Discharge Current @50Hz 1S	Impulse Life @10/1000 μ S 100A
		Max	Max			Nominal \pm 5 times	Max 1 time	Nominal 5 times	Min
		V	V			G Ω	pF	KA	KA
2R075-4S	75 \pm 20%	500	600	1	0.8	3	6	3	300
2R090-4S	90 \pm 20%	500	600	1	0.8	3	6	3	300
2R150-4S	150 \pm 20%	500	600	1	0.8	3	6	3	300
2R230-4S	230 \pm 20%	600	700	1	0.8	3	6	3	300
2R250-4S	250 \pm 20%	600	700	1	0.8	3	6	3	300
2R300-4S	300 \pm 20%	750	850	1	0.8	3	6	3	300
2R350-4S	350 \pm 20%	800	900	1	0.8	3	6	3	300
2R400-4S	400 \pm 20%	850	950	1	0.8	3	6	3	300
2R470-4S	470 \pm 20%	900	1000	1	0.8	3	6	3	300
2R600-4S	600 \pm 20%	1100	1200	1	0.8	3	6	3	300
2R800-4S	800 \pm 20%	1300	1400	1	0.8	3	6	3	300
Glow Voltage at 10mA.....					~60V				
Arc Voltage at 1A.....					~10V				
Glow to Arc transition Current.....					~0.3A				
Weight.....					~0.26g				
Operation and storage temperature.....					-40~+90°C				
Climatic category (IEC 60068-1).....					40/90/21				
Marking, blue negative.....					XXX Y XXX -Nominal voltage Y -Year of production				
Surface treatment.....					Matte-tin plated				

¹⁾ At delivery AQL 0.65 level II, DIN ISO 2859

²⁾ In ionized mode

³⁾ Insulation Resistance Measuring Voltage:

75V at DC 25V

90V~150V at DC 50V

Other at DC 100V

Terms in accordance with ITU-T Rec. K.12, IEC 61643-311, GB/T 9043.

Dimensions

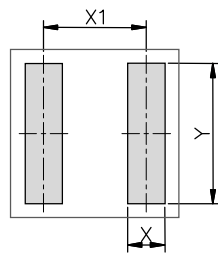
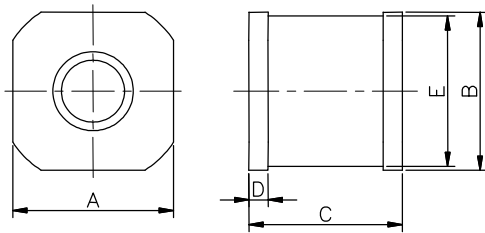

Recommended Soldering Pad Layout

Symbol	Millimeters	Inches
A	4.2±0.2	0.165±0.008
B	4.2±0.2	0.165±0.008
C	4.0±0.3	0.157±0.012
D	0.5±0.1	0.020±0.004
E	Φ4.0±0.1	Φ0.157±0.004
X	1.3	0.051
X1	3.6	0.142
Y	5.0	0.197

Taping and Reel Specifications

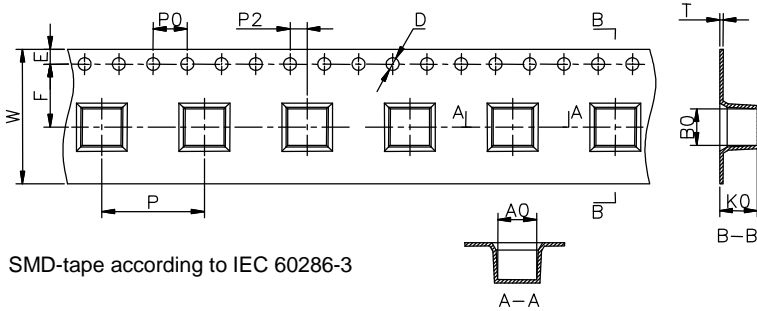

SMD-tape according to IEC 60286-3

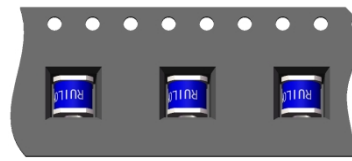
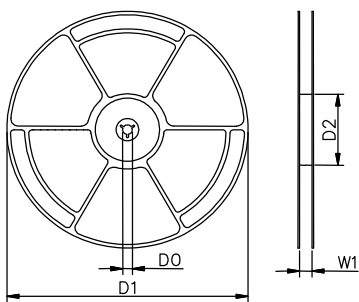

Direction of Unreeling

Symbol	Millimeters	Inches
W	16±0.3	0.630±0.012
A0	4.5±0.1	0.177±0.004
B0	4.3±0.1	0.17±0.004
K0	4.4±0.1	0.173±0.004
P	12±0.1	0.472±0.004
F	7.5±0.1	0.295±0.004
E	1.75±0.1	0.069±0.004
D	1.5+0.1/-0.0	0.059+0.004/-0.0
P0	4±0.1	0.157±0.004
P2	2±0.1	0.079±0.004
T	0.4±0.1	0.016±0.004
D0	13.3±0.15	0.524±0.006
D1	330±2	12.992±0.079
D2	100+1/-2	3.937+0.039/-0.079
W1	16.5±0.4	0.65±0.016

Packaging Quantity:

- 1,000 PCS per reel (13")
- 3 reels per inner box
- 3,000 PCS per inner box

Soldering Parameters - Reflow Soldering (Surface Mount Devices)

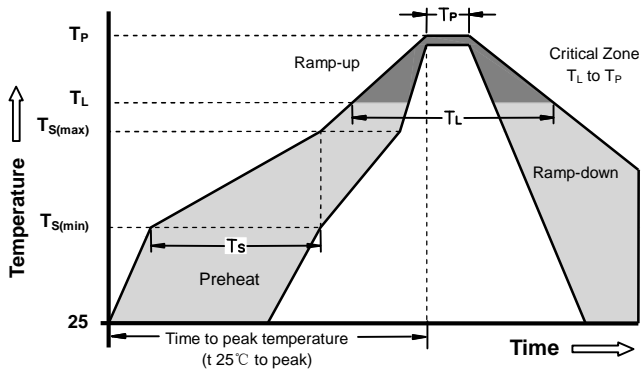

Reflow Condition		Pb - Free assembly
Pre Heat	-Temperature Min ($T_{s(min)}$)	150°C
	-Temperature Max ($T_{s(max)}$)	200°C
	- Time (min to max) (t_s)	60 -180 Seconds
Average ramp up rate (Liquids Temp T_L to peak		3°C/second max
$T_{s(max)}$ to T_L - Ramp-up Rate		5°C/second max
Reflow	- Temperature (T_L) (Liquids)	217°C
	- Time (min to max) (t_s)	60 -150 Seconds
Peak Temperature (T_P)		260 +0/-5°C
Time within 5°C of actual peak Temperature (t_p)		10 - 30 Seconds
Ramp-down Rate		6°C/second max
Time 25°C to peak Temperature (T_P)		8 minutes Max
Do not exceed		260°C